

## Description

A resonant inductive position sensor for measuring linear position over small distances. Works with CambridgeIC's Central Tracking Unit (CTU) family of single chip processors to provide high-quality position data to a host device.

The sensor requires only 3 connections, and is Type 4. CTU chips should be configured and connected accordingly.

The sensor is available as a blueprint in Gerber format, to enable integration with a customer's own PCB. It is also available as an assembled sensor for evaluation, customer prototyping and low-volume production.

## Features

- Simple non-contact target
- Standard 4-layer PCB process
- Stable across temperature
- Highly repeatable
- Small footprint

## Performance

- $< \pm 0.25\%$  Linearity Error over 5mm at 1mm Gap
- Noise Free Resolution  $\leq 5\mu\text{m}$  at 1mm Gap with CTU
- Up to  $\pm 1\text{mm}$  Y Misalignment
- Valid Length  $\geq 19\text{mm}$
- Up to 5mm Target Gap

## Applications

- Thickness measurement
- Structural monitoring
- Vibration analysis
- Actuator position feedback
- LVDT replacement

Product identification	
Part no.	Description
013-0016	Assembled sensor
013-6001	300mm ribbon connector
013-1005	Compatible target
010-0037	Sensor Blueprint

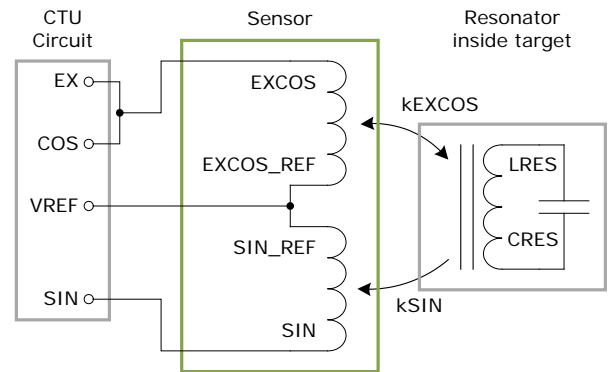

Figure 1 equivalent circuit

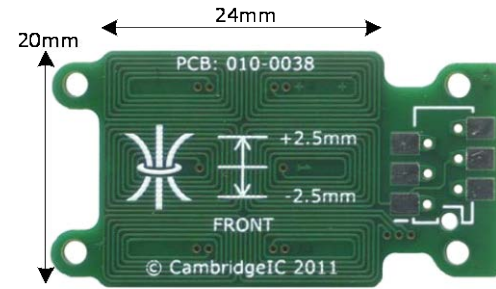
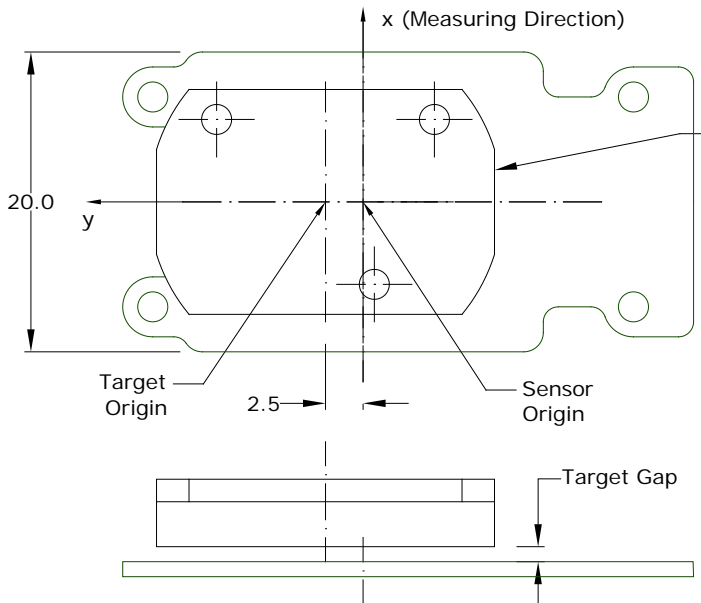

Figure 2 assembled sensor (without connector)



target 013-1005  
either way up (can flip about y axis as shown)  
may be placed above Front or below Rear of sensor

All dimensions in mm

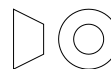
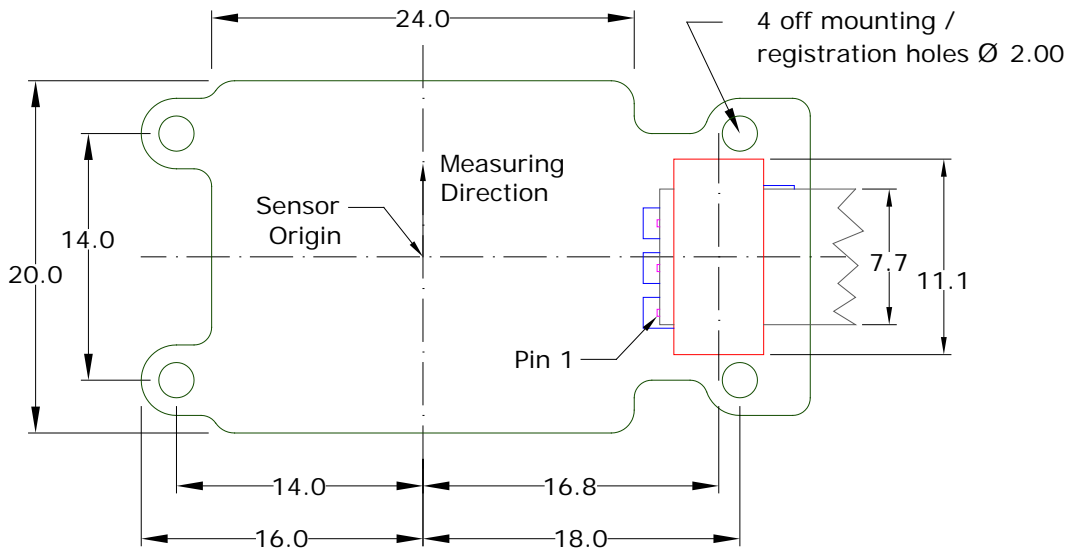

Figure 3 assembled sensor shown with target part number 013-1005

# 1 Assembled Sensor



All dimensions in mm

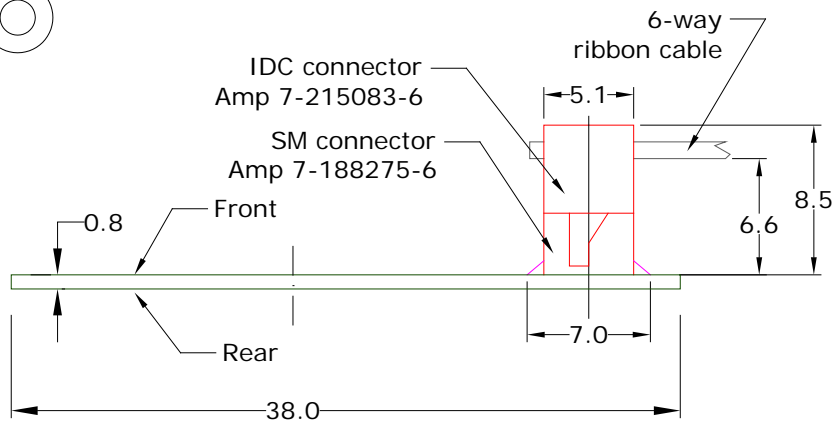

Figure 4 assembled sensor, shown with connector 013-6001 attached

Figure 4 defines the position of the Sensor Origin, which is nominally the origin of the Sensor Blueprint data. The sensor is also available in the form of a Sensor Blueprint (section 3).

## 2 Performance

This section illustrates performance of the linear sensor. Figures are representative of assembled sensors available from CambridgeIC (as described in section 1) and of sensors built according to CambridgeIC's blueprint (section 3). Measurements are taken with a typical target (part number 013-1005) and CAM204BE CTU chip.

### 2.1 Alignment of Target and Sensor

The sensor is intended for use with CambridgeIC's standard target, part number 013-1005. This should be positioned relative to the sensor as illustrated in Figure 3. The sensor coil pattern is symmetric on reflection about the x-axis. The 2.5mm nominal offset to the target in the y-direction is due to the target's asymmetry: the coil inside is offset from centre.

The sensor measures displacement of the target in the x-direction (up and down as drawn). It is highly tolerant to displacement in the y-direction, and a tolerance of ±1mm is specified for the purpose of performance measurement.

### 2.2 Transfer Function

The CTU reports position as a 16-bit signed number: *CtuReportedPositionI16*. It also outputs a VALID flag to indicate when the target is in range. Figure 5 illustrates how these outputs change with the Actual Position of the target (Actual Position is defined in Equation 2). Note that the CTU's output spans less than half full scale of 65536 when used with the Short Stroke Sensor.

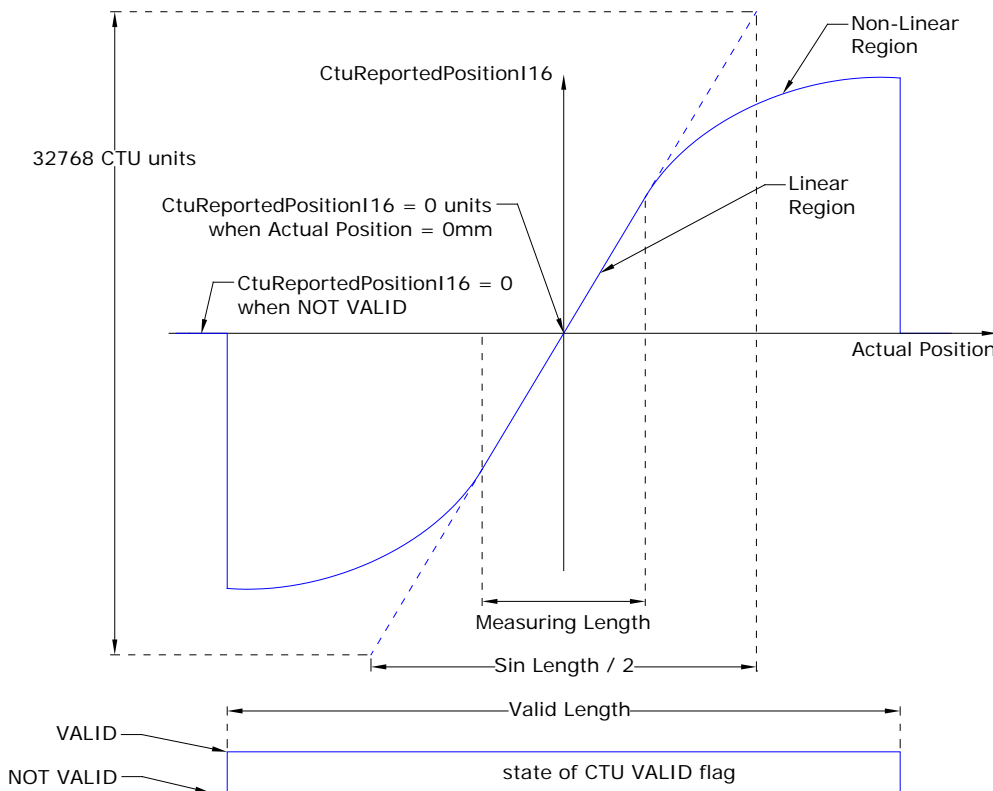

**Figure 5** CTU outputs versus position

The *Measuring Length* defines a central region where the measurement of position is linear. Different values may be selected, resulting in different worst-case non-linearity. The distance over which the CTU reports VALID is the *Valid Length*. For the Short Stroke Linear Sensor, Valid Length can be much greater than Measuring Length.

*Sin Length* defines how *CtuReportedPositionI16* can be scaled into distance units:

$$ReportedPosition = \frac{CtuReportedPositionI16}{65536} \times SinLength + PositionOffsetError$$

**Equation 1**

*Sin Length* is almost constant. It changes slightly with Target Gap.

The system is designed so that *Position Offset Error* is nominally zero. Position Offset Error is almost entirely due to mechanical tolerances of the sensor and target. In some cases Position Offset Error may be known (e.g. through a “zero calibration”), in which case the known value may be used to improve the estimate of Reported Position.

### 2.3 Performance Metrics

Absolute Position Error is the difference between Reported Position and Actual Position. A fixed, quoted value for Sin Length is used (typically Sin Length at a stated Target Gap), and a value of 0 is used for Position Offset Error:

$$\text{AbsolutePositionError} = \text{ReportedPosition} - \text{ActualPosition} \quad [\text{value of Sin Length fixed, Position Offset Error} = 0]$$

#### Equation 2

According to this definition, Absolute Error includes the error in position alignment between the resonator inside the target and the features used to define the Target Origin (two mounting holes in the case of target 013-1005). This document concerns the sensor alone, and performance is quoted excluding this Target Position Offset.

Absolute Position Error may also be quoted as a percentage of the Measuring Length:

$$\text{AbsolutePositionError}\% = \frac{\text{AbsolutePositionError}}{\text{MeasuringLength}} \times 100\%$$

#### Equation 3

Linearity Error is defined in the same way as Absolute Position Error, except that the values of Sin Length and Position Offset Error are modified to minimise the maximum error. This definition corresponds to Independent Linearity (INL).

$$\text{LinearityError} = \text{ReportedPosition} - \text{ActualPosition} \quad [\text{values of Sin Length and Position Offset Error variable}]$$

#### Equation 4

Note that Independent Linearity is scaled to the same position units as Absolute Position, by definition. It may also be quoted as a percentage:

$$\text{LinearityError}\% = \frac{\text{LinearityError}}{\text{MeasuringLength}} \times 100\%$$

#### Equation 5

Unless otherwise stated, all measurements are based on the average of a sufficiently large number of individual CTU samples so that the effect of CTU noise is negligible. Noise (and resolution) are functions of the CTU which depend on Amplitude (section 2.7).

### 2.4 Valid Length

Valid Length is the distance over which the system reports VALID, as illustrated in Figure 5. It depends on the distance between the target and sensor: Target Gap.

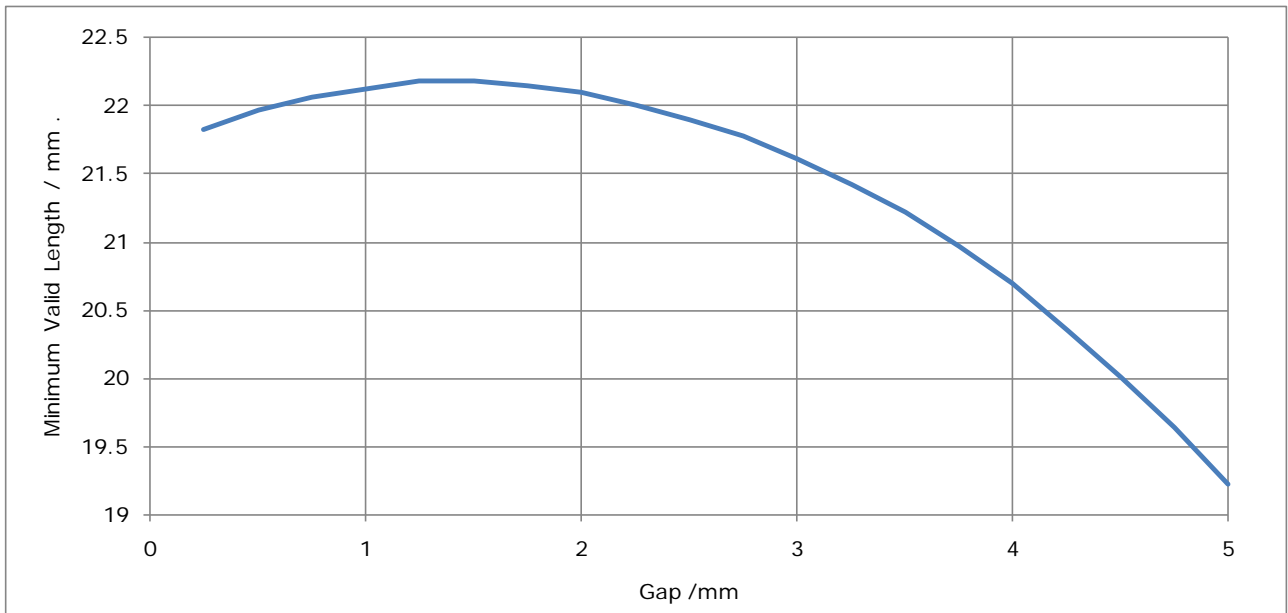

Figure 6 Valid Length as a function of Target Gap

### 2.5 Linearity Error

Linearity Error is a measure of accuracy defined above in Equation 4 (in mm) and Equation 5 (as %). The *Worst Linearity Error* refers to the worst error magnitude measured across the Measuring Range. Figure 7 and Figure 8 show how Worst Linearity Error depends on Target Gap for a typical sensor, measured with Y Misalignment = 0mm. The sensor may be used over different Measuring Lengths, with linearity generally improving with shorter values.

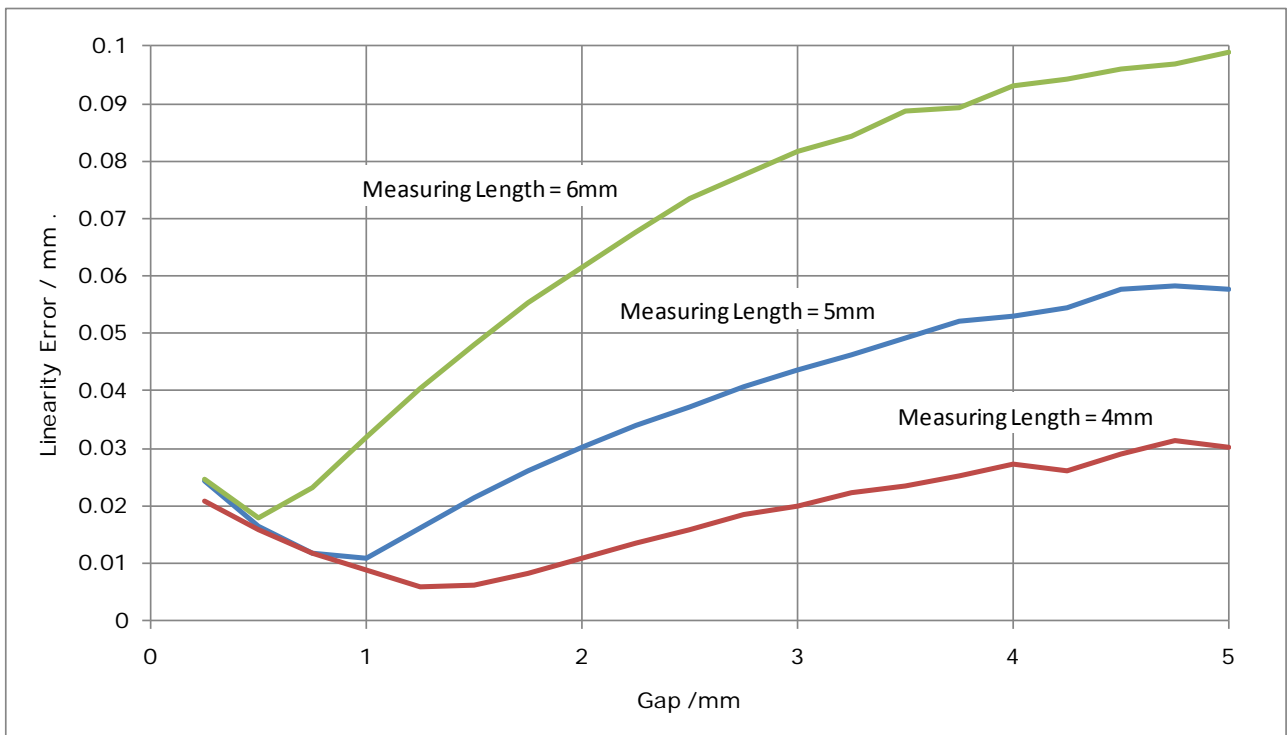

Figure 7 Linearity Error in mm as a function of Target Gap for different Measuring Lengths

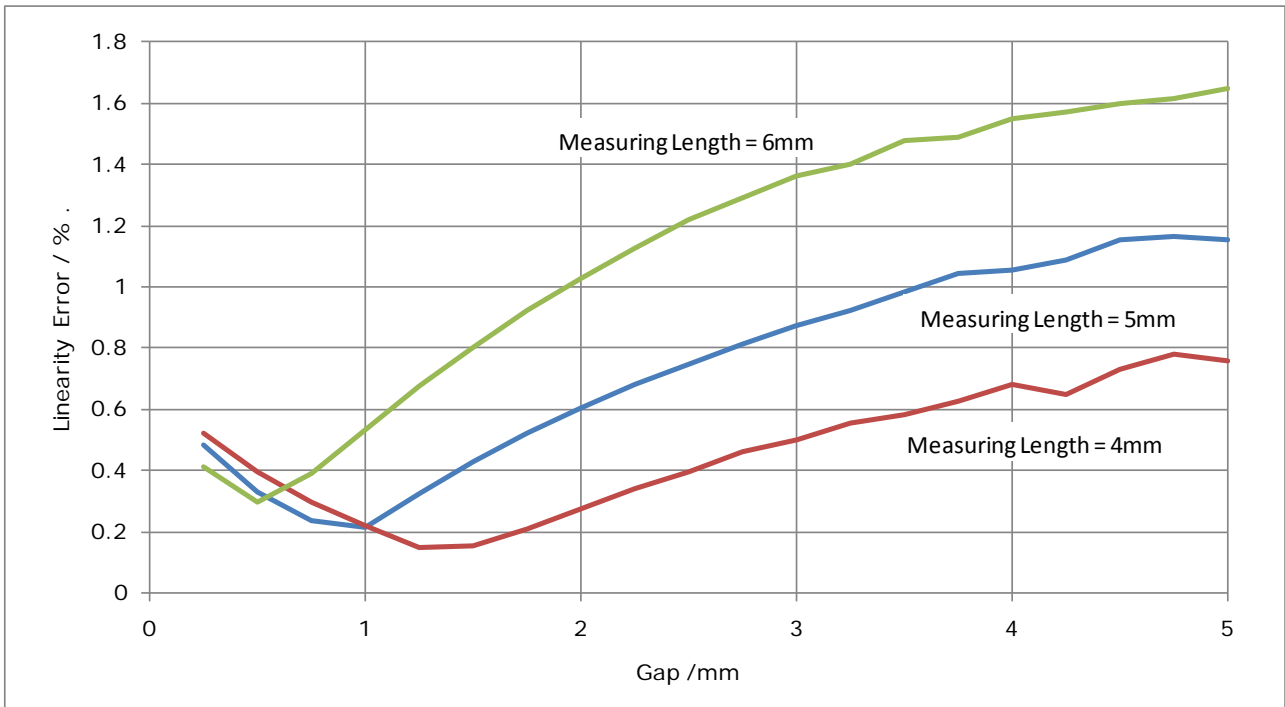

Figure 8 Linearity Error in % as a function of Target Gap for different Measuring Lengths

### 2.6 Sin Length Dependence on Target Gap

The value of Sin Length required minimise Linearity Error changes slightly with Target Gap, as illustrated in Figure 9.

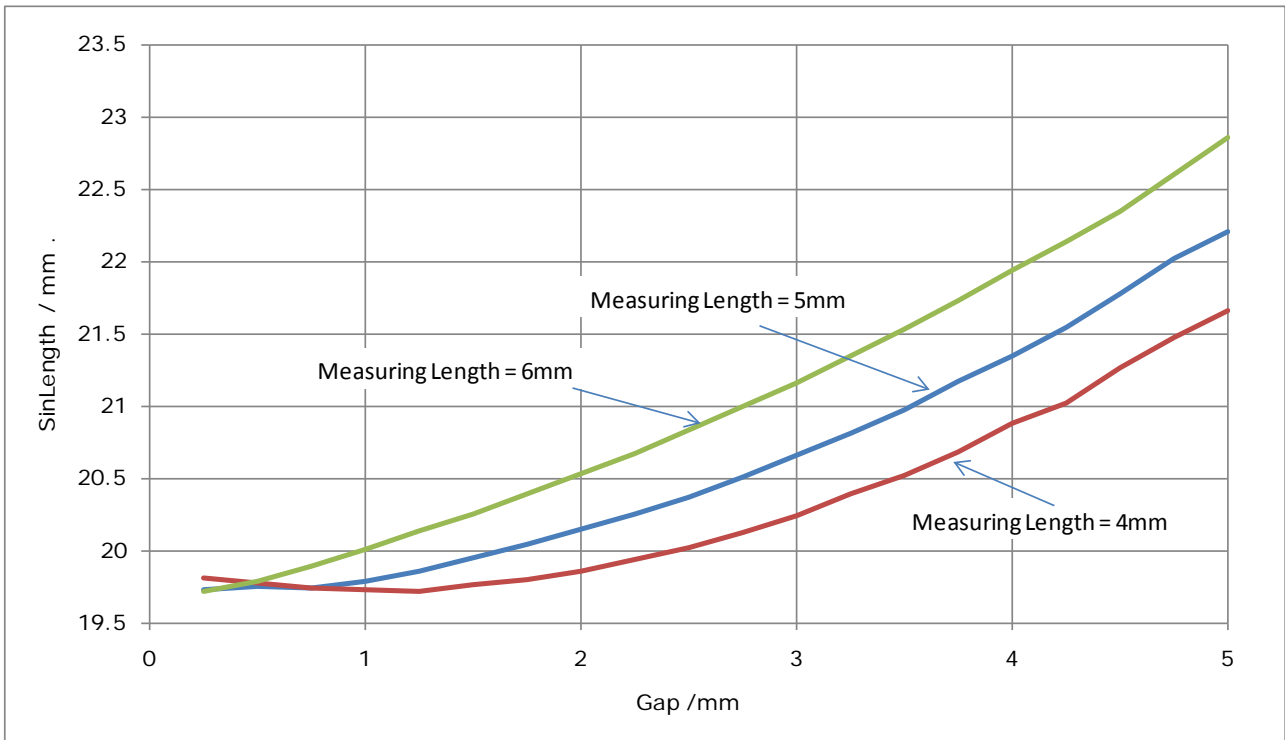

Figure 9 Sin Length dependence on Target Gap

Figure 9 defines the best scaling factor to convert measurements reported by the CTU to mm using Equation 1.

## 2.7 Amplitude

Amplitude is one of the reported measurement results from a CTU chip. It is a measure of inductive signal coupling between the sensor and target. Higher values are preferable since they result in better resolution when the sensor is used with a CTU chip. Amplitude may be used as a coarse measure of Target Gap, and is a useful system diagnostic measurement. Figure 10 shows how Amplitude changes with Target Gap and x-position.

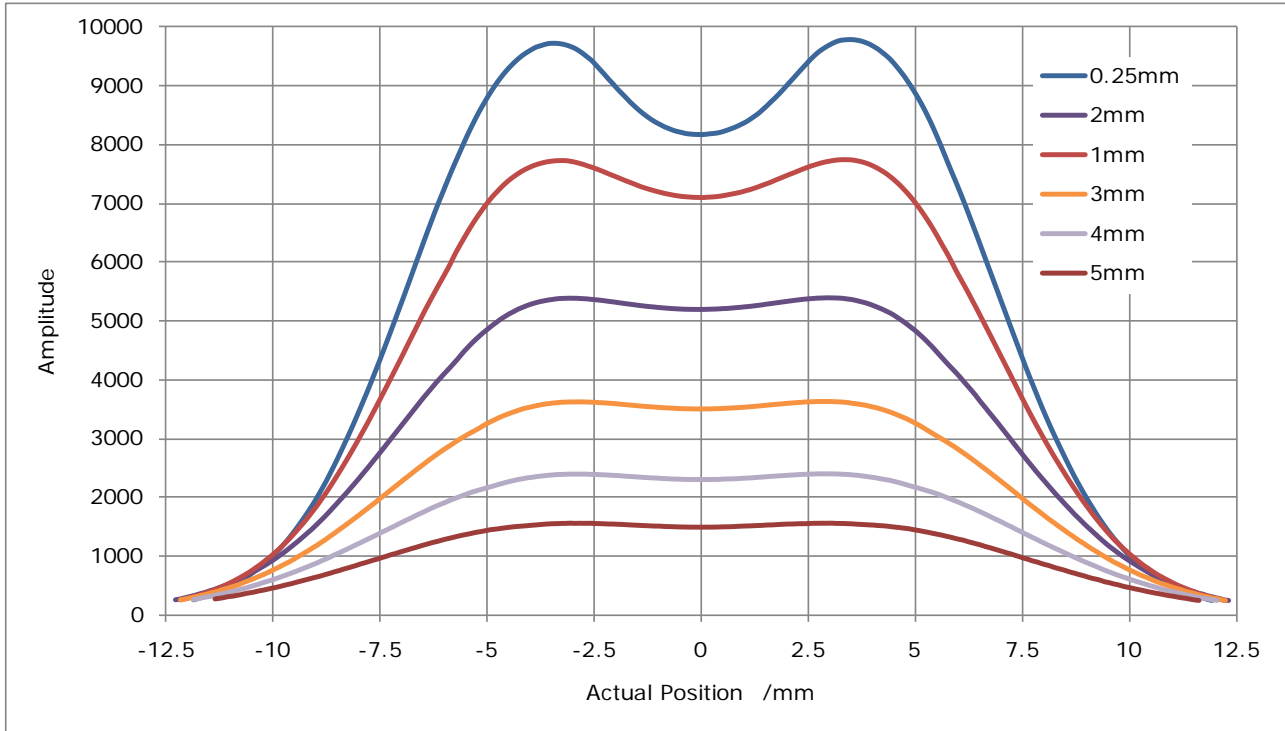

Figure 10 Amplitude reported by CTU versus x-position for different values of Target Gap

### 3 Sensor Blueprints

#### 3.1 Purpose

A sensor blueprint comprises Gerber (RS274-X) data defining the pattern of conductors required to build the sensors onto a PCB. A customer may build their own sensors for use with CambridgeIC's CTU family of processors, either as stand-alone sensors or combined with their own circuitry.

#### 3.2 Fabrication Technology

The sensor blueprint is fabricated on a 4-layer PCB.

Table 1

Copper thickness	oz	µm
Minimum	0.8	28
Recommended	≥1	≥35
Ideal	2	70

#### 3.3 PCB Design Parameters

Table 2

PCB Design Rules	Minimum values used	
	mm	inches
Track width	0.2	0.008
Gap between tracks	0.2	0.008
Via land outer diameter	0.8	0.031
Drill hole diameter	0.4	0.016

#### 3.4 PCB Integration

Figure 11 illustrates the extent of the copper pattern required to build the sensor on a PCB. The rectangular area is the sensor itself, with coil connections shown to the right. The coil pattern may be rotated or flipped to fit a customer's assembly, in which case the position reported by the CTU will be transformed accordingly.

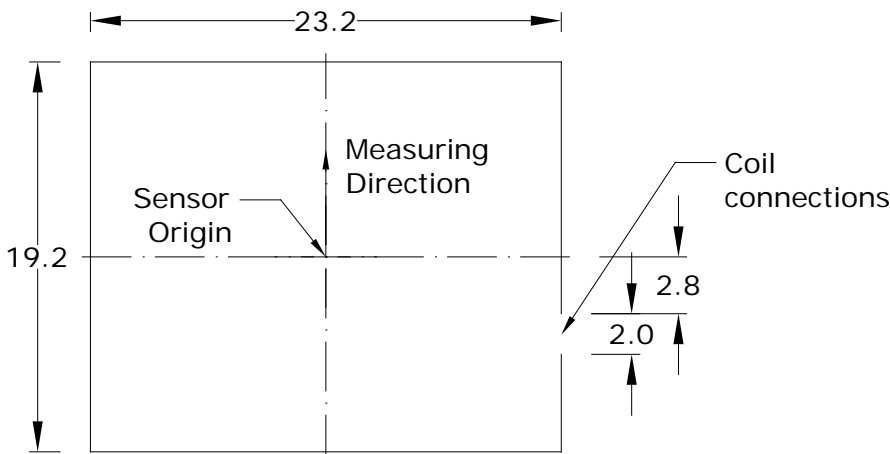

Figure 11 copper extents

#### 3.5 Trace Connections

The sensor has two pairs of tracks, which should be connected to the respective CTU circuit connections with the minimum practical trace lengths. One pair is used for both sensing and excitation (EXCOS, EXCOS\_REF). Connections to these signals should have minimum resistance, preferably by using traces 0.5mm wide or more. The other pair is for sensing alone (SIN, SIN\_REF).

Tracks are routed in pairs, and each member of a pair should follow the same path as the other, on different

and preferably adjacent layers, to minimise errors due to unbalanced loops.

EXCOS\_REF and SIN\_REF may be connected together at the sensor to yield 3 connections as illustrated in Figure 1. If this is done, all 3 connections should run together.

Whether joined at the sensor or separate, EXCOS\_REF and SIN\_REF should be connected to the CTU circuit's VREF node as close as possible to the CTU circuit.



## 4 Environmental

Assembled sensors conform to the following environmental specifications:

Item	Value	Comments
Minimum operating temperature	-40°C	Limited by specification of connector
Maximum operating temperature	105°C	
Maximum operating humidity	95%	Non-condensing

Sensors built to Sensor Blueprints can operate in more extreme conditions by choice of materials and encapsulation.

## 5 Document History

Revision	Date	Comments
0001	8 February 2011	First draft
0002	13 February 2014	Added patent numbers

## 6 Contact Information

Cambridge Integrated Circuits Ltd  
 21 Sedley Taylor Road  
 Cambridge  
 CB2 8PW  
 UK

Tel: +44 (0) 1223 413500

web: <http://www.cambridgeic.com>

email: [info@cambridgeic.com](mailto:info@cambridgeic.com)

## 7 Legal

This document is © 2011-2014 Cambridge Integrated Circuits Ltd (CambridgeIC). It may not be reproduced, in whole or part, either in written or electronic form, without the consent of CambridgeIC. This document is subject to change without notice. It, and the products described in it ("Products"), are supplied on an as-is basis, and no warranty as to their suitability for any particular purpose is either made or implied. CambridgeIC will not accept any claim for damages as a result of the failure of the Products. The Products are not intended for use in medical applications, or other applications where their failure might reasonably be expected to result in personal injury. The publication of this document does not imply any license to use patents or other intellectual property rights.

The design of the sensor, comprising each of the patterned copper layers, drill locations, silk screens, assembly layers and board outline are protected by copyright.

The parts described in this datasheet are subject to the following patents: US8570028B2, GB2461448B. Other patents are pending.